

Solution Tank

Assembly Part No: 2638

POS	PART NUMBER	DESCRIPTION	#
1	VP03214	PLAST.TANK HANDLE	1
2	VP02622	SCREW "TC" 4,2X16 INOX	4
3	VP02598	SMALL BUCKET COVER	1
4	VP02597	SMALL BUCKET LT.6	1
5	VP02580	FLOAT	1
6	VP02622	SCREW "TC" 4,2X16 INOX	1
7	VP02592	FILTER	1

Filter

Assembly Part No: 3293

POS	PART NUMBER	DESCRIPTION	#
1	VP02655	FILTER BASKET LAVA	1
2	VP00123	FILTER RING 300	1
3	VP00124	FILTER BAG VH0151/101	1

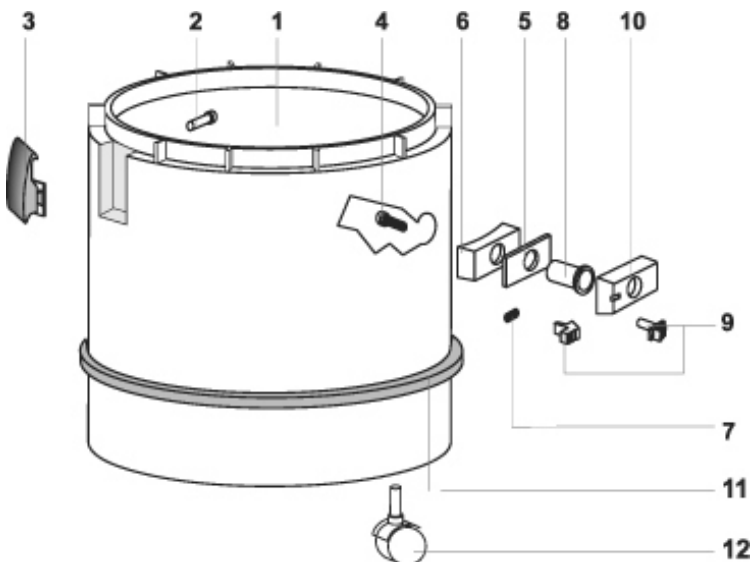
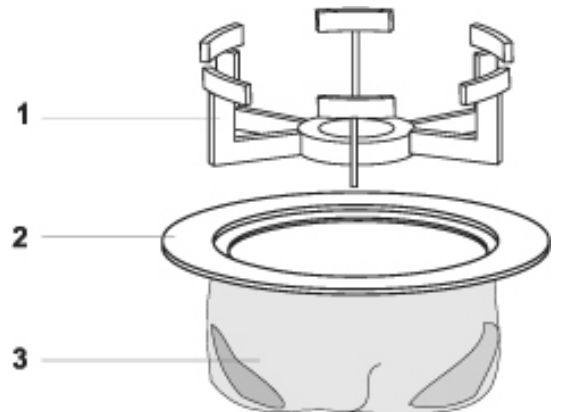

Tank

Assembly Part No: 2644

POS	PART NUMBER	DESCRIPTION	#
1	VP02643	TANK	1
2	VP01300	RIVET 5X24,5	4
3	VP01847/S	HOOK PLASTIC COMPLETE	2
4	VP01026	SCREW 5X30	4
5	VP02846	GASKET D.38	1
6	VP02586	GASKET R 205	1
7	VP02608	SPRING SPIRAL 99	1
8	VP02767	DEFLECTOR	1
9	VP02594	INLET BUTTON	1
10	VP02583	INLET 99	1
11	VP02630	ANTI-SHOCK BAND	1
12	VP00558	TROLLEY WHEEL BOX	4