

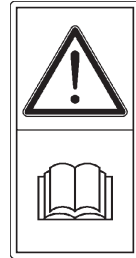

OPERATING & MAINTENANCE MANUAL

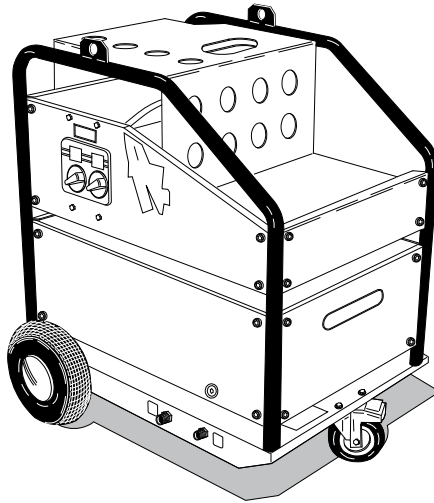

FIREBOX BOILER MODELS 30 - 40

**Read Safety & Operating Instructions
Before Commencing Operation**

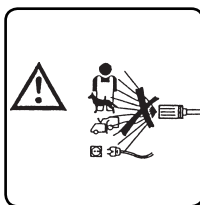

NON DIRIGERE IL GETTO CONTRO PERSONE, ANIMALI, PRESE DI CORRENTE SULLA MACCHINA STESSA.

DO NOT DIRECT THE JET AGAINST PEOPLE, ANIMALS, POWER SOCKETS OR THE MACHINE ITSELF.

NE PAS DIRIGER LE JET VERS LES PERSONNES, LES ANIMAUX, LES PRISES DE COURANT ET L'APPAREIL LUI-MEME.

ATTENZIONE PERICOLO DI FOLGORAZIONE.

ATTENTION: RISK OF ELECTRIC SHOCK
ATTENTION: DANGER D'ELECTROCUTION
ACHTUNG: FUNKENGEFAHR
ATENCIÓN: PELIGRO DE ELECTROCUTACIÓN
ATENÇÃO: PERIGO DE FULMINAÇÃO.
ВНИМАНИЕ: ОПАСНОСТЬ УДАРА ЭЛЕКТРИЧЕСКИМ ТОКОМ.
OPGELET, GEVAAR VOOR ELEKTRISCHE SCHOKKEN

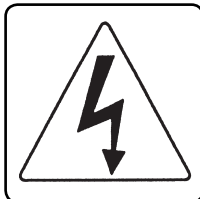

INGRESSO ACQUA.
WATER INPUT
ARRIVEE DE L'EAU
WASSEREINLAUF
SALIDA DE AGUA
ENTRADA DE ÁGUA.
ВХОД ДЛЯ ВОДЫ.
INGANG WATER.

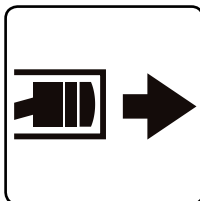

ACCENSIONE BRUCIATORE.

LIGHTING THE BURNER
ALLUMAGE BRULEUR
EINSCHALTEN DES BRENNERS
ENCENDIDO QUEMADOR.
LIGAÇÃO DO QUEIMADOR.
ЗАЖИГАНИЕ ГОРЕЛКИ.
ONTSTEKING BRANDER.

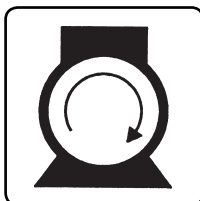

CARBURANTE (GASOLIO).
FUEL (DIESEL).
CARBURANT (GASOIL)
TREIBSTOFF (DIESEL)
CARBURANTE (GASOIL)
CARBURANTE (GASÓLIEO).
ТОПЛИВО (ДИЗЕЛЬ).
BRANDSTOF (DIESELolie).

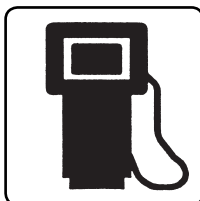

DEN STRAHL NICHT AUF PERSONEN, TIERE, STECKDOSEN ODER DIE MASCHINE SELBST RICHTEN.

NO DIRIGIR EL CHORRO CONTRA PERSONAS, ANIMALES, TOMAS DE CORRIENTE EN LA MISMA MÁQUINA.

NÃO VIRE O JACTO DE ÁGUA CONTRA PESSOAS, ANIMAIS, TOMADAS DE CORRENTE, OU CONTRA A PRÓPRIA MÁQUINA.

НЕ НАПРАВЛЯЙТЕ СТРУЮ НА ЛЮДЕЙ, ЖИВОТНЫХ, ЭЛЕКТРИЧЕСКИЕ РОЗЕТКИ ИЛИ САМО УСТРОЙСТВО.

RICHT DE STRAAL NIET OP PERSONEN, DIEREN, STOPCONTACTEN OF OP DE MACHINE ZELF.

ATTENZIONE: PERICOLO DI USTIONE.

ATTENTION: RISK OF BURNS
ATTENTION: DANGER DE BRULURE
ACHTUNG: VERBRENNUNGSGEFAHR
ATENCIÓN PELIGRO DE QUEMADURAS
ATENÇÃO: PERIGO DE QUEIMADURA.
ВНИМАНИЕ: РИСК ВОЗГОРАНИЯ.
ATTENTIE: VERBRANDINGSGEVAAR.



MESSA TERRA.
EARTH
MISE A LA TERRE
ERDUNG
DESCARGA A TIERRA
LIGAÇÃO À TERRA.
ЗАЗЕМЛЕНИЕ.
AARDING.

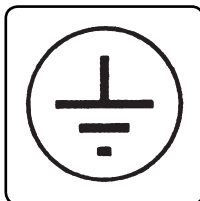

USCITA ACQUA.
WATER OUTPUT
EVACUATION DE L'EAU
WASSERABLAUF
SALIDA DE AGUA
SAÍDA DE ÁGUA.
ВЫХОД ДЛЯ ВОДЫ.
UITGANG WATER.

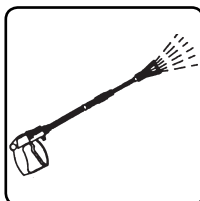

REGOLAZIONE TEMPERATURA ACQUA.
ADJUSTING THE WATER TEMPERATURE
REGLAGE TEMPERATURE DE L'EAU
REGULIERUNG DER WASSERTEMPERATUR
REGULACIÓN TEMPERATURA AGUA
REGULAÇÃO DA TEMPERATURA DA ÁGUA.
РЕГУЛИРОВКА ТЕМПЕРАТУРЫ ВОДЫ.
REGELING WATERTEMPERATUUR.

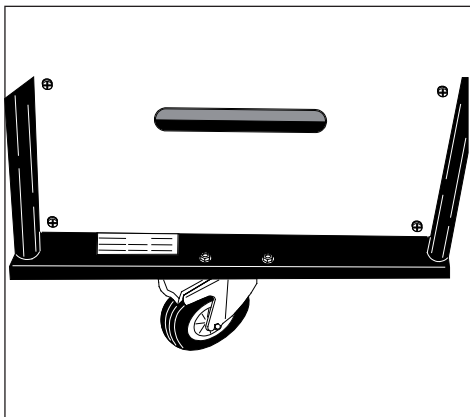
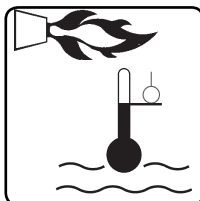

Fig. 1

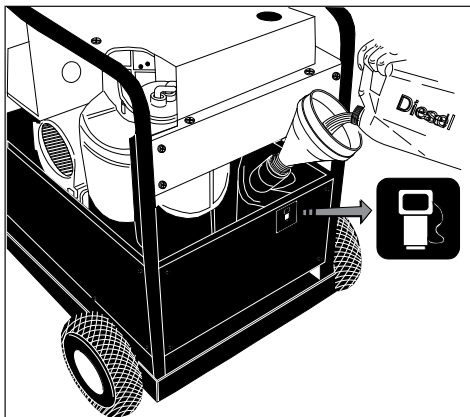

Fig. 2

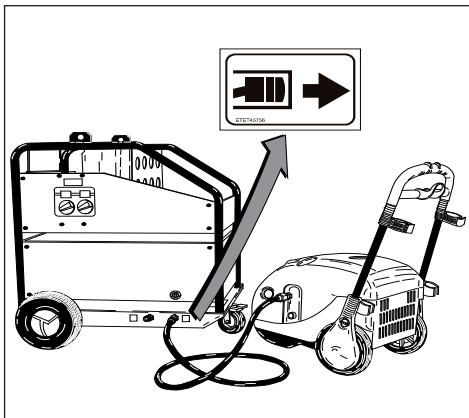

Fig. 3

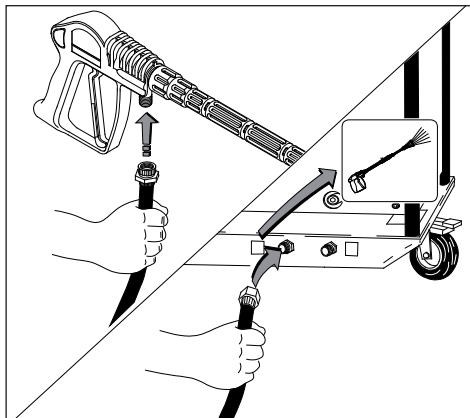

Fig. 4

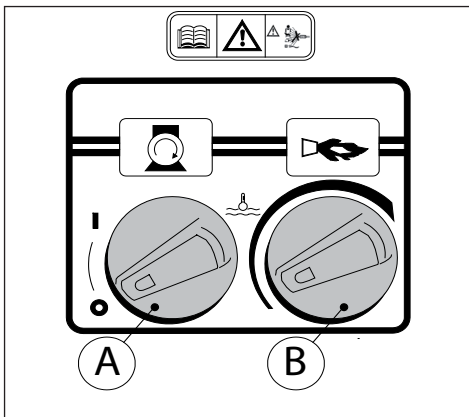

Fig. 5

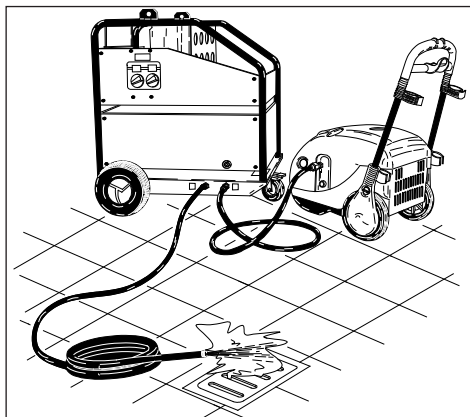

Fig. 6

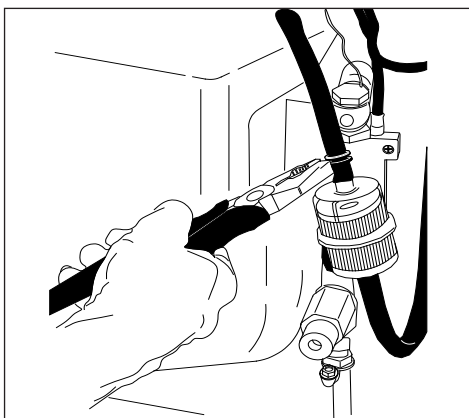

Fig. 7

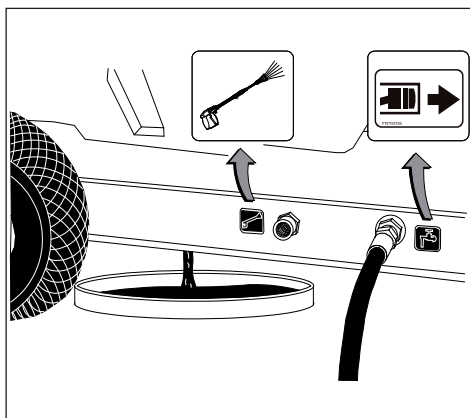

Fig. 8

TRANSLATION OF ORIGINAL INSTRUCTIONS

This text has been carefully checked. Should any printing errors be noted, these should be communicated to the manufacturer.

We reserve the right to update this publication without notice.

The most important instructions are marked with the symbol:



FOREWORD



This manual must be read before assembling, starting and using the appliance. It is an integral part of the product itself.

Read the warnings and instructions contained in this booklet carefully. They provide important information on the **safe use** and **maintenance** of the appliance. Pay particular attention to general safety instructions.

Keep this booklet in a safe place for future consultation.

This hot water generator is constructed in accordance with current regulations and standards.

The contents of this booklet should be brought to the attention of the user.

CLASSIFICATION

The user of this appliance must respect the specified operating conditions with particular regard to the following classification:

For the purposes of protection against electric shock, this hot water generator is classified as a **class 1** appliance.



The hot water generator is adjusted in the factory and all safety devices are sealed. **Their adjustment must on no account be altered.**

The hot water heat generator for heating water is **diesel** fuelled.

The hot water generator must always be used on solid flat ground. It must not be moved while in function or when connected to the mains power supply.

The hot water heat generator is considered as a fixed installation.

Failure to comply with the above could constitute a source of danger.

The hot water generator must not be used in corrosive or potentially explosive atmospheres (vapours or gas). Electrical connections must be carried out in respect of current legislation (in Italy, in compliance with the provisions of law 46/90) and in accordance with the manufacturer's instructions.

Check that the electrical installation and sockets are adequate for the maximum power of the appliance as indicated on the rating plate (W).

If in doubt, consult a qualified electrician.

The correct plug should be fitted by a qualified electrician.

The manufacturer declines all liability for damage to persons, animals or things caused by faulty or incorrect connection.



Before connecting the hot water generator, check that the specification given on the rating plate corresponds to that of the mains electricity supply.

If the appliance is connected via an extension, use cable with an adequate cross section (never less than 2.5 mm²) and fitted with a waterproof plug and socket.

The electrical safety of the appliance is guaranteed only when correctly and efficiently earthed as specified in current electrical safety legislation (in Italy, in compliance with the provisions of law 46/90).

This fundamental safety requisite should be verified. If in doubt, ask a professionally qualified electrician to check the system thoroughly.

The manufacturer declines all liability for damage caused by faulty earthing of the appliance.

The appliance can be disconnected from the mains only by unplugging the plug from the mains socket.

APPLICATIONS

The unit is designed exclusively for the production of hot water for use with a high pressure water cleaner. Any other use is considered improper and/or incorrect.

Examples of improper and/or incorrect use:

- Using the hot water generator in the rain.
- Using the appliance to clean animals, people, etc.
- Moving the hot water generator by pulling the electric cable.
- Using the hot water generator with a damaged electric cable.
- Cleaning the hot water generator with water jets.
- Cleaning the appliance when plugged into the mains.
- Using the hot water generator with wet hands and/or feet.
- Leaving the hot water generator unsupervised while running.
- Using the hot water generator without the guards (panels, grills).
- Obstructing ventilation and heat dispersal apertures or slits.

- Using unsuitable fuel, leading to at-risk situations.
- Using the equipment alone (not in combination with a high pressure water cleaner).



Use only original accessories offering maximum quality and security. Failure to use original accessories absolves the manufacturer from all liability.

PRELIMINARY OPERATIONS

Unpacking:

After unpacking the appliance, check it is complete and undamaged.

If in doubt, do not use the hot water generator. Contact your local dealer. Packaging (bags, boxes, nails etc) should be kept out of reach of children as they may represent a potential hazard. They should be disposed of or kept according to the environmental legislation in force in the country concerned.

Assembling parts supplied separately

All main parts and safety devices are assembled by the manufacturer. Certain other secondary parts may be supplied separately.

These parts must be assembled by the user following the assembly instructions.



Identification plate:

On purchase, make sure the product has an identification plate. If this is missing, notify the manufacturer and/or dealer immediately.

Use of an appliance without an identification plate absolves the manufacturer from all liability. Products without an identification plate should be considered as anonymous and potentially dangerous.

The main technical characteristics of the hot water generator are given on a plate applied to the front of the appliance (fig. 1).

The user must ensure that the rooms where the hot water generator is to be used comply with all safety standards and regulations in terms of:

- efficient electrical installations;
- the absence of explosive, inflammable, toxic or corrosive substances.

Use of the appliance in particular conditions requiring use of class II appliances only is not recommended.

Filling the fuel tank

Fill the fuel tank with diesel (fig. 2).



Do not use fuel other than that indicated on the rating plate. While the hot water generator is in function, check the fuel level regularly. Functioning without fuel could damage the diesel pump.

CONNECTING TO THE WATER MAIN

Connect the water supply pipe to the coupling on the water cleaner and the inlet coupling on the hot water generator (fig. 3).

Connect the H.P. pipe supplied with the high pressure water cleaner to the output of the hot water generator and the lance (fig. 4).

Connect the H.P. water cleaner to the mains water supply, following the instructions in the accompanying manual.

Maximum temperature of inflow water: 50°C (122°F)

Electrical connections

The hot water generator should be connected to the mains in accordance with current legislation (in Italy, law 46/90)

Make sure the mains voltage corresponds to the voltage required by the appliance and indicated on the rating plate (fig. 1).



Protect the electric cable from accidental crushing.

Failure to respect the above conditions absolves the manufacturer from all liability and represents negligent use of the product.

Protection against accidental contact.

Before removing the panels, unplug the appliance from the mains. Before using the appliance, make sure the closing panels are correctly mounted and fastened.

Failure to respect these instructions could result in electric shock and absolves the manufacturer from all liability.

GENERAL WARNINGS

1 When using any electrical appliance, certain fundamental rules should be respected:

- do not touch the appliance with wet hands or feet;
- do not use the appliance with bare feet or unsuitable clothing;

- do not pull the power cable or appliance itself to unplug the plug from the mains.

2 The hot water generator should not be used by children, adolescents or other persons unfit to operate it (for example, while drunk).

3 Keep people away from the appliance while it is working.

4 Do not use the appliance in the rain.

5 Do not obstruct ventilation and heat dispersal apertures or slits.

6 In the event of breakdown or malfunction, turn the appliance off. Do not attempt to repair it. Contact our technical service centre.

7 Do not use the hot water generator if the power cable is damaged. To replace it, contact our technical service centre only.

8 Do not clean the appliance with water jets.

9 Use suitable personal protection (gloves, masks, etc).

10 The appliance must never be left unattended when in function.

11 If the appliance is used in a closed room, install a fume evacuation system and ventilate the room adequately.

USING THE HOT WATER GENERATOR

Control panel (fig. 5)

A – Main ON/OFF switch 0-I

B – Water temperature regulator.

Turning the hot water generator on:

To turn the hot water generator on, place the main ON/OFF switch in the “I” position (fig. 5).

Rotate the temperature regulator B to the required value according to the type of washing and surface to be treated (fig. 5).

Start up the water cleaner, following the instructions in the accompanying manual.



To eliminate impurities or air bubbles from the water circuit, turn the water cleaner and generator on for the first time without the lance and allow the water to run for several seconds.

Impurities could block the nozzle and prevent it operating (fig. 6).

Turning the hot water generator off

To turn the appliance off, place the temperature regulator B in the “min” position and the main ON/OFF switch A to “0”. Unplug from the mains electricity supply.

Turn the appliance on and off by means of the main switch only and never by plugging in or unplugging the mains plug.



Never unplug by pulling the power cable.



Operate the H.P. water cleaner for at least 30 seconds to cool the boiler.

Turn the H.P. water cleaner off, following the instructions in the accompanying manual.

Important

In common with all other technical appliances, your hot water generator must always be used according to the instructions.



After use, disconnect the hot water generator from the H.P. water cleaner and empty the water circuit of residual fluids, disposing of the contents in accordance with current regulations.

Do not dispose of residual fluids in the environment.

MAINTENANCE

Only maintenance authorised in this booklet may be carried out by the user. All other operations are prohibited.



Before carrying out maintenance of any kind, unplug the hot water generator from the mains.

The appliance can be disconnected from the mains only by unplugging the plug from the mains socket.

When maintenance has been completed, before reconnecting the hot water generator to the mains, check that the panels have been replaced correctly and fixed using the screws provided.

FROST PROTECTION

The hot water generator most not be allowed to freeze.

After use or when stored for long periods, if there is a risk of temperatures below freezing point, the hot water generator must be detached from the water cleaner, the water circuit emptied and the residual fluids disposed of in accordance with legislation in force in the country concerned.

Cleaning the filter and diesel tank.

Remove the filter on the diesel circuit and replace it.
 Replace regularly (fig. 7).
 Empty the diesel tank.
 Using the drainage bung (fig. 8), drain any impurities present into a container.
 Rinse the tank with clean diesel and close the drainage hole.

DESCALING

The appliance must be descaled regularly to avoid the risk of calcium in the water building up in and blocking the water circuit and coil.
This should be done by an authorised technical service centre and will increase the efficiency of the heat generator.

STORAGE

If the hot water generator is not used for long periods, unplug from the mains socket and protect parts which might be damaged by dust. Empty the water circuit and rinse with clean water.
 When used again, check there are no cracks or cuts in the feed pipe.

SCRAPPING

If you decide to stop using the hot water generator, you should render it inoperative by removing the electric power cable. Parts which might constitute a danger, especially to children playing with the appliance, should be made harmless.

The hot water generator is classified as special waste. It must be taken apart and divided into uniform sections which should be disposed off according to legislation in force in the country concerned.

Do not use the components removed as spare parts.

STANDARD KIT

H.P. feed pipe l = 3.0 m

TECHNICAL CHARACTERISTICS

		30	40 - 40/35
Boiler volume	l	3,9	5,0
Min. flow rate	l/min.	6	6
Max. flow rate	l/min.	21	21
Working pressure	bar	175	200-350
Water temp.	°C	140°	140°
Heat input	W	300	300
Heat output	kW	67	88
Diesel tank	l	18	18
Weight	Kg	92	105
Noise level	Lp dB (A)	69	69

TROUBLESHOOTING

Problem

The appliance does not work.

Cause

No voltage.
 Faulty cable or mains switch.

Remedy

Make sure there is voltage.
 Contact the service centre.

Problem

When the thermostat reaches the set temperature, the boiler does not come on.

Cause

No diesel.
 Clogged diesel filters.

Remedy

Check the level of diesel in the fuel tank. Check the state of cleanliness of the fuel intake circuit (presence of water). Replace the circuit filter.

Problem

Water not hot enough.

Cause

Thermostat calibration.
 Clogged filters.
 Boiler coil blocked with scale.

Remedy

Check.
 Clean diesel filters.
 Contact the service centre.

Problem

Excessive smoking from flue.















Cause

No diesel.
 Incorrect fuel.
 Fuel contaminated with impurities or water.

Remedy

Fill diesel tank.
 Clean diesel filters. Contact authorised service centre.
 Empty the tank and clean thoroughly. Clean the various diesel filters.

Technical Data

	• Model		FIRE 30	FIRE 40	FIRE 40/35
	• Power supply	~ v Hz	230/240 50	230/240 50	230/240 50
	• Absorbed power	kW W	0,3 300	0,3 300	0,3 300
	• Pressure	bar psi	175 (max) 2500 (max)	200 (max) 2900 (max)	350 (max) 5100 (max)
	• Flow rate	l/h gph	360 ÷ 1260 95 ÷ 333	360 ÷ 1260 95 ÷ 333	360 ÷ 1260 95 ÷ 333
	• Fuel consumption	kg/h	5,8	7,4	7,4
	• Thermal capacity	gph kW	1,53 67	1,95 88	1,95 88
	• Water out-put temperature	°C °F	30 ÷ 140 86 ÷ 284	30 ÷ 140 86 ÷ 284	30 ÷ 140 86 ÷ 284
	• Fuel tank	l gal	18 4,8	18 4,8	18 4,8
	• Detergent tank	l gal			
	• Discaling tank	l gal			
	• High pressure hose	m ft	3,0 9,8	3,0 9,8	3,0 9,8
	• Power cable	m ft	5,5 18	5,5 18	5,5 18
	• Lance thrust	N			
	• Noise	Lp dB (A) Lw dB (A)	69 83	69 83	69 83
	• Weight	kg lb	92 203	105 231,5	105 231,5
	• Dimensions	cm in	79x75x92 31x29,5x36,2	79x75x92 31x29,5x36,2	79x75x92 31x29,5x36,2

KERRICK SERVICING

Kerrick's workshop facilities are staffed by experienced technicians providing servicing, repair and manufacturing for a range of products including; water blasters, vacuum cleaners, extractors, pressure cleaners, pumps and more.

We work on everything from commercial and light industrial to large heavy duty equipment and offer customized design build services. We also warehouse and ship a comprehensive range of spare parts for your convenience.

For more information on your product, to book in a service or repair, or to order spare parts, give Kerrick a call or send through an enquiry on our website. Contact details can be seen below:

KERRICK NEW ZEALAND

0800 2 KERRICK (0800 253 774)
SALES@KERRICK.CO.NZ
WWW.KERRICK.CO.NZ

KERRICK AUSTRALIA

1300 KERRICK (1300 537 742)
SALES@KERRICK.COM.AU
WWW.KERRICK.COM.AU